

Replacing String Rollers

Tooling:

1 flathead screwdriver with a width as close as possible to the width of the screw (not wider than).

When replacing the string rollers, do this one roller at a time.

It is important to keep each gear in the same position and not to mix them up.

1. Unwind the black screw while holding the string roller to the back of the side-plate and remove the screw.
2. Hold the gear in position with a finger and pull out the string roller.
3. Push new roller into position lining up the square.
4. Wind the screw back in and tighten lightly with the screwdriver.

To check correct positioning of the 'spring washer', move the string roller from side to side.

If it is not loose and springs back square to the side-plate, this is correct.

Wind the button to make sure it feels ok and not tight.

If it is not correct, remove the string roller and re-align the spring washer.

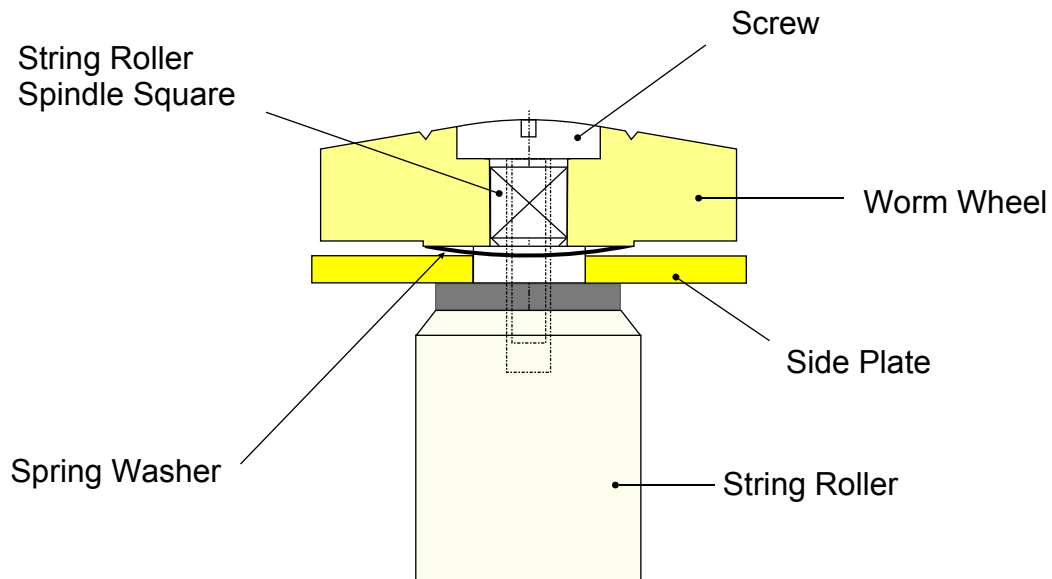

When assembling the tuner, ensure that the Spring washer is located around the diameter of the string roller spindle and that the worm wheel is seated correctly on the spindle flange. See Below. String roller should not wobble loosely.

